





BELLA
our beauty



BELLA

our beauty



Bella convinces by her beauty.
The curved frontpanel and frontglass, her perfect proportions,
the inclination of tubs and the strong LED illumination enables
perfect visibility of Gelato.

Bella überzeugt durch ihre Schönheit.
Die runde Front, ihre perfekten Proportionen sowie die Neigung
der Eisbehälter und die starke LED-Beleuchtung ermöglicht
die beste Sicht auf das Speiseeis.





MARISA
our star



MARISA

our star



Every detail of the **MARISA** is carefully composed.
The Perfect Combination :
Practical Classic with modern Design.

Jede Einzelheit von **MARISA** sind genau durchdacht.
Die perfekte Kombination :
Praktischer Klassiker mit modernem Design.

Perfect product visibility
through perfect inclination of gelato tubs.
Optimale Sicht auf das Speiseeis
durch perfekte Neigung der Eisbehälter.





LUXURY
our elegance



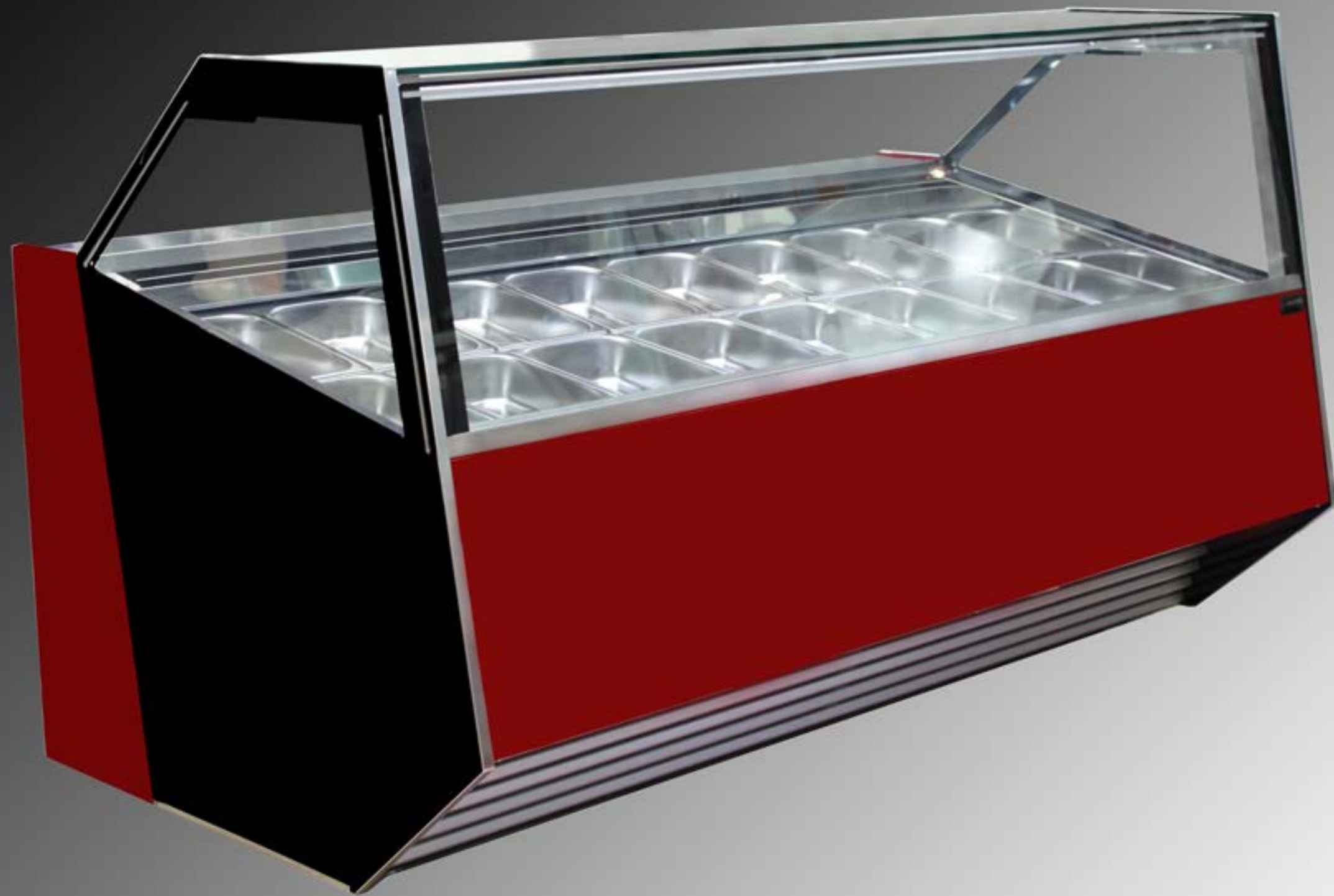

Translation of attractive design and technology :
our most luxurious cabinet **LUXURY**.

Übersetzung von attraktivem Design und Technologie :
unsere neues luxerioses Vitrine **LUXURY**.

Inclination of Front goes over from Glas to Panel.
Special Sideglas is making from **LUXURY**
one design furniture with perfect visibility on Gelato.

Vordere Neigung geht vom Glas zum Paneel über.
Spezialseitenglas macht aus **LUXURY**
ein Designmöbelstück mit perfekter Sicht auf Gelato.



TECHNICAL SPECIFICATIONS

BELLA

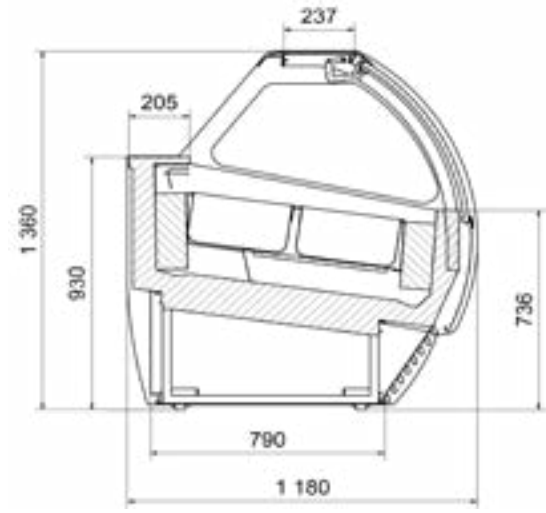

	BELLA 12G ICE CREAM CABINET	BELLA 16G ICE CREAM CABINET	BELLA 20G ICE CREAM CABINET	BELLA 24G ICE CREAM CABINET
Size	1180 x 1180 x 1360 mm l x d x h	1506 x 1180 x 1360 mm l x d x h	1830 x 1180 x 1360 mm l x d x h	2205 x 1180 x 1360 mm l x d x h
Number of ice cream bins	16 360x165mm 8 360x250mm	16 360x165mm 10 360x250mm	20 360x165mm 12 360x250mm	24 360x165mm 16 360x250mm
Power supply	400 V / 3 / 50Hz			
Total power	2100 W	2600 W	2900 W	3360 W
Total power of defrosting	2300 W	2800 W	3200 W	3850 W
Compressor power	1230 W	1420 W	1720 W	1860 W
Net weight	250 kg	300 kg	370 kg	420 kg
Refrigerant	R 404A			
Temperature range	-10°C / -22 °C			
Climate class	35°C / RH 70%			

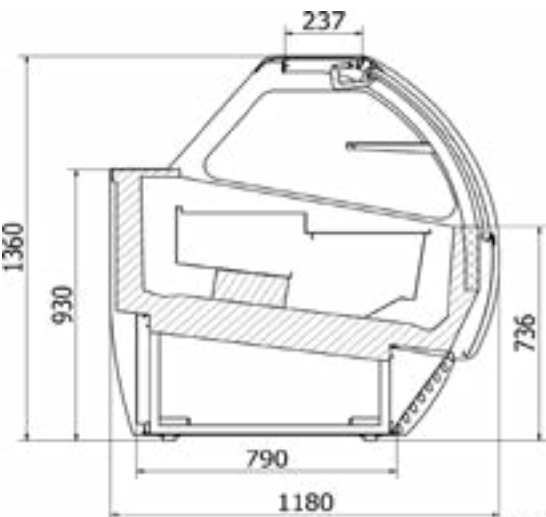

	BELLA 12P PASTRY CABINET	BELLA 16P PASTRY CABINET	BELLA 20P PASTRY CABINET	BELLA 24P PASTRY CABINET
Size	1180 x 1180 x 1360 mm l x d x h	1506 x 1180 x 1360 mm l x d x h	1830 x 1180 x 1360 mm l x d x h	2205 x 1180 x 1360 mm l x d x h
Power supply	230 V / 1 / 50Hz			
Total power	1000 W	1100 W	1210 W	1320 W
Net weight	250 kg	300 kg	370 kg	420 kg
Refrigerant	R 134A			
Temperature range	+4°C / +8 °C			

TECHNICAL SPECIFICATIONS

MARISA

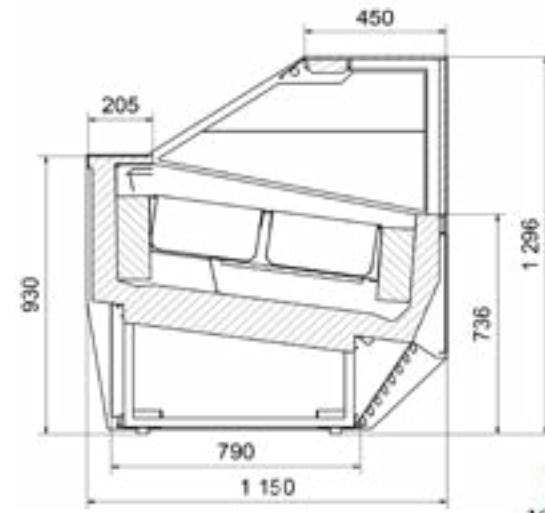

	MARISA 12G ICE CREAM CABINET	MARISA 16G ICE CREAM CABINET	MARISA 20G ICE CREAM CABINET	MARISA 24G ICE CREAM CABINET	MARISA 32G ICE CREAM CABINET
Size	1175 x 1150 x 1290 mm l x d x h	1506 x 1150 x 1290 mm l x d x h	1830 x 1150 x 1290 mm l x d x h	2205 x 1150 x 1290 mm l x d x h	2960 x 1150 x 1290 mm l x d x h
Number of ice cream bins	16 360x165mm 8 360x250mm	16 360x165mm 10 360x250mm	20 360x165mm 12 360x250mm	24 360x165mm 16 360x250mm	32 360x165mm 22 360x250mm
Power supply	400 V / 3 / 50Hz				
Total power	2100 W	2600 W	2900 W	3360 W	3580 W
Total power of defrosting	2300 W	2800 W	3200 W	3850 W	4320 W
Compressor power	1230 W	1420 W	1720 W	1860 W	2240 W
Net weight	250 kg	300 kg	370 kg	420 kg	550 kg
Refrigerant	R 404A				
Temperature range	-10°C / -22 °C				
Climate class	35°C / RH 70%				

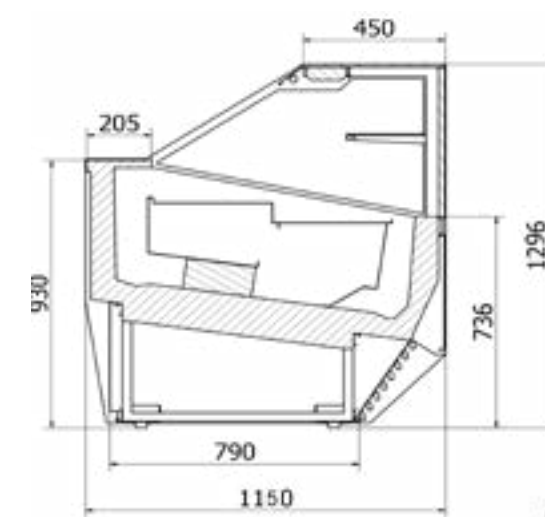

	MARISA 12P PASTRY CABINET	MARISA 16P PASTRY CABINET	MARISA 20P PASTRY CABINET	MARISA 24P PASTRY CABINET
Size	1175 x 1150 x 1290 mm l x d x h	1506 x 1150 x 1290 mm l x d x h	1830 x 1150 x 1290 mm l x d x h	2205 x 1150 x 1290 mm l x d x h
Power supply	230 V / 1 / 50Hz			
Total power	1000 W	1100 W	1210 W	1320 W
Net weight	230 kg	280 kg	350 kg	400 kg
Refrigerant	R 134A			
Temperature range	+4°C / +8 °C			

TECHNICAL SPECIFICATIONS

LUXURY

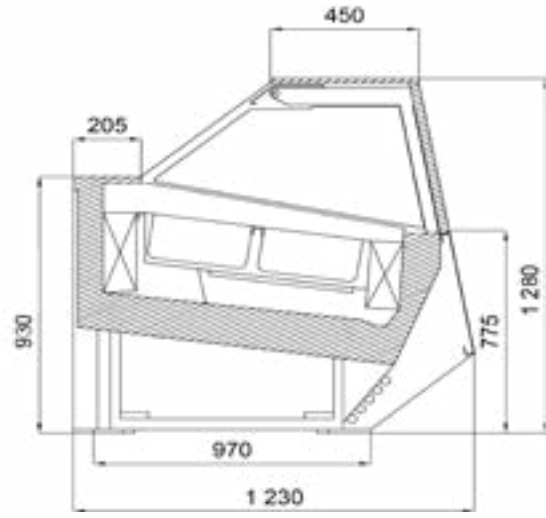

LUXURY 12G
ICE CREAM CABINET

LUXURY 16G
ICE CREAM CABINET

LUXURY 20G
ICE CREAM CABINET

LUXURY 24G
ICE CREAM CABINET

Size	1178 x 1230 x 1280 mm l x d x h	1509 x 1230 x 1280 mm l x d x h	1833 x 1230 x 1280 mm l x d x h	2208 x 1230 x 1280 mm l x d x h
Number of ice cream bins	16 360x165mm 360x250mm	8 360x165mm 360x250mm	16 360x165mm 360x250mm	10 360x165mm 360x250mm
Power supply	400 V / 3 / 50Hz	400 V / 3 / 50Hz	400 V / 3 / 50Hz	400 V / 3 / 50Hz
Total power	2100 W	2600 W	2900 W	3360 W
Total power of defrosting	2300 W	2640 W	3200 W	3850 W
Compressor power	1230 W	1420 W	1720 W	1860 W
Net weight	250 kg	300 kg	370 kg	420 kg
Refrigerant	R 404A			
Temperature range	-10°C / -22 °C			
Climate class	35°C / RH 70%			

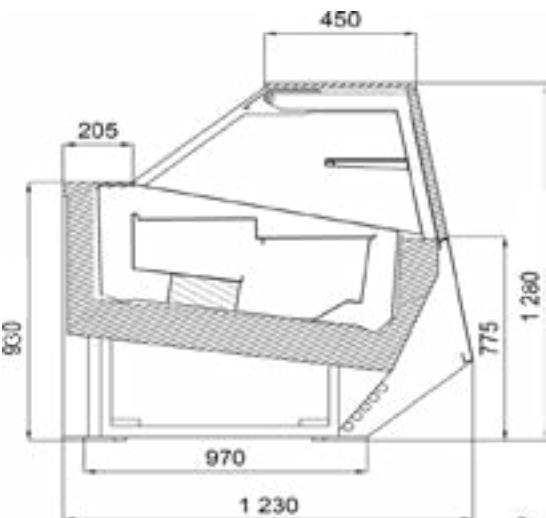

LUXURY 12P
PASTRY CABINET

LUXURY 16P
PASTRY CABINET

LUXURY 20P
PASTRY CABINET

LUXURY 24P
PASTRY CABINET

Size	1178 x 1230 x 1280 mm l x d x h	1509 x 1230 x 1280 mm l x d x h	1833 x 1230 x 1280 mm l x d x h	2208 x 1230 x 1280 mm l x d x h
Power supply	230 V / 1 / 50Hz	230 V / 1 / 50Hz	230 V / 1 / 50Hz	230 V / 1 / 50Hz
Total power	1000 W	1100 W	1210 W	1320 W
Net weight	230 kg	280 kg	350 kg	400 kg
Refrigerant	R 134A			
Temperature range	+4°C / +8 °C			

tough, reliable, trendy

stabil, verlässlich, trendy



Heated and airchambered double GLASSES (Front / Side)
Beheizte, doppelte ISOLIERGLÄSER
(Front - / Seitenglas)

Hydraulically openable.

Hydraulisch aufklappbar.



CURTAIN
Closing with curtain in the back.

ROLLO
Hinten mit Rollo schliessbar.
Rollo mit Bremswirkung.



PROFILES
Small Profiles allow to see both rows of Gelato.

PROFILE
Schmale Profile ermöglichen die Sicht auf beide Reihen von Gelato.



WIDE TOP
Enough space on the smooth top.

BREITE ABLAGEFLÄCHE
Genug Platz auf der oberen glatten Fläche. Keine Schmutzfugen.

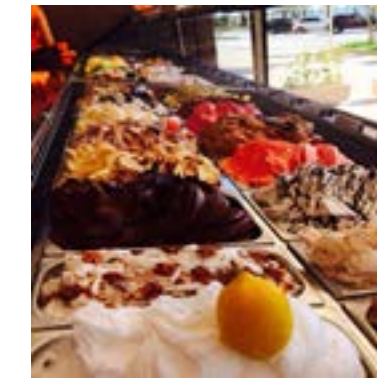

BIG MOUNTAINS OF GELATO
Linear air flow for hills of Gelato.

BERGEIS
Lineare Luftströmung ermöglicht grosse Eisberge.



REFRIGERATION
Strong ventilated Refrigeration through large, coated and double evaporators.

KÜHLUNG
Starke Umluftkühlung durch grosse, beschichtete und doppelte Verdampfer.



EASY CLEAN
Easy Clean Lid for Condenser.

EASY CLEAN
Easy Clean Deckel für den Verflüssiger.



COMPRESSOR / DEFROSTING
Semi - seal Dorin Compressor with automatic.
Reverse Cycle Defrosting System.

KOMPRESSOR / ABTAUUNG
Semihemetischer Dorin Kompressor mit automatischer Abtauung mittels Umkehrventil.

PASTRY CABINETS

KUCHENVITRINEN

Our Pastry cabinets have the same design like Gelato Cabinets, that we can assemble them together with Gelato Cabinets without sideglass and -panels. Pastry Cabinets have also strong insulation with a thickness of 80 mm, all front- and sideglasses are double and airchambered. Slow ventilation through a big evaporator enables high level of moisture inside of the cabinet.

Unsere Kuchenvitrinen haben die selbe Design wie die Eisvitrinen und sind mit den Eisvitrinen ohne Seitenglas und -paneel kombinierbar. (Kanalierbar) Kuchenvitrinen haben auch starke Isolierung von 80 mm, alle Front- und Seitengläser sind doppelt und isoliert. Langsame Umluftkühlung durch einen großen Verdampfer ermöglicht eine relativ hohe Luftfeuchtigkeit im Inneren der Vitrine.



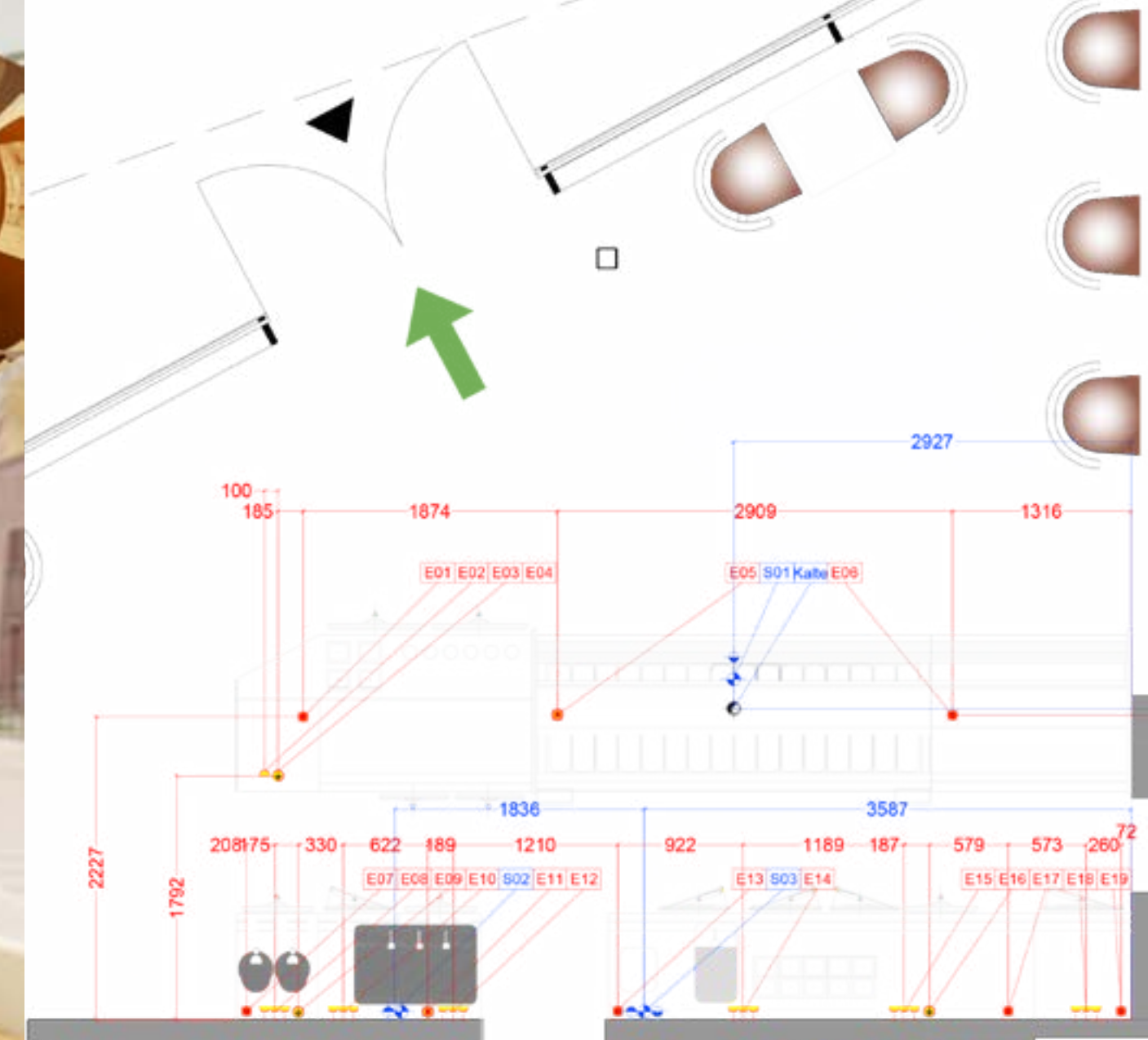

Shops

Ladenbau



GLOBALLY YOUR LA SQUADRA

You can find our cabinets in 47 countries worldwide.

Sie können unsere Eisvitrine in 47 Länder weltweit finden.



LA SQUADRA
e i s v i t r i n e n



LEDRA, s.r.o.

Headquarter:

Farská 42
949 01 Nitra
Slovakia

Factory:

Hlavná 1246
951 36 Veľké Zálužie
Slovakia



Tel: +49 174 454 63 08

+ 421 915 752 882

+ 421 905 403 478

E-Mail: sales@lasquadra.de

www.lasquadra.de